

SINTERLEGHE

Your needs. Our quality.

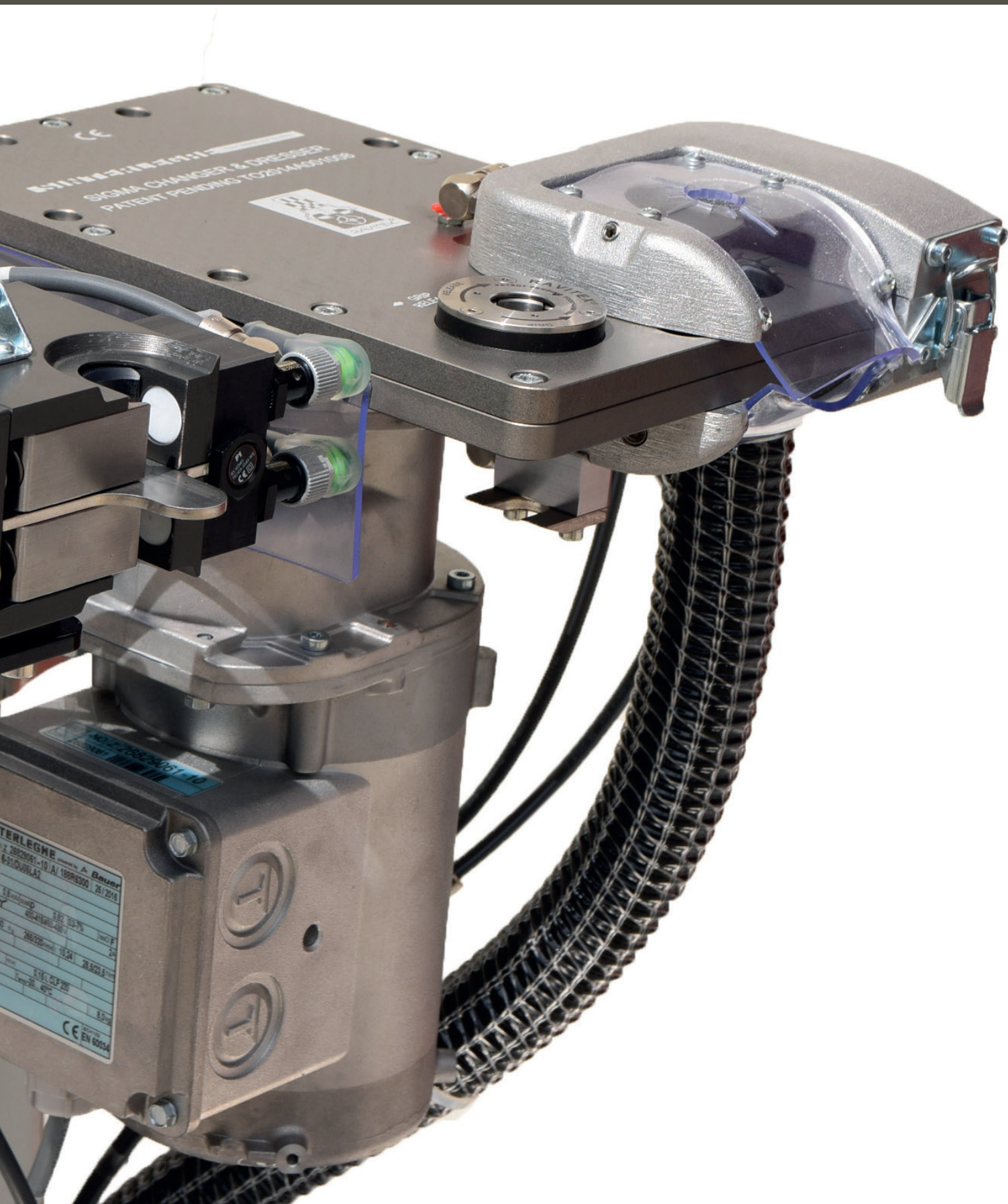

WHO WE ARE

SINTERLEGHE is world leader in the *design, manufacture and sale of tip dressers, electrode tip changers and metal cutters* for resistance welding electrodes, *supplying* major car manufacturers.

SINTERLEGHE is specialized in the design and manufacturing of tip dressers, electrode tip changers and metal cutters for spot welding electrode tip dressing.

Established in 1989 by **Eugenio Tedeschi**, the company developed its know-how, which allowed it to grow and differentiate its offer by reaching **high qualitative standards**.

The tenacity and perseverance in accomplishing its goals allowed SINTERLEGHE to devise new **design solutions** that ultimately became **patents**. This is an added value to a company that made innovation and technology

evolution its strength. Today SINTERLEGHE is a key partner for large international groups involved in car manufacturing.

Since 1992 its products, made in the facility of Anzola d'Ossola (VB), have been known all over the world with the brand **Ravitex®**, sold in 4 continents and 23 Countries.

With offices in Marburg, Germany, and Sao Paulo, Brazil, and its **partnership** networks (including an agreement with Shanghai Faith Co., Ltd. for the Chinese market), SINTERLEGHE controls and supplies the European, Asian, US and South American markets.



OUR CUSTOMERS



OUR PRODUCTS ARE INSTALLED IN 4 CONTINENTS AND 23 COUNTRIES

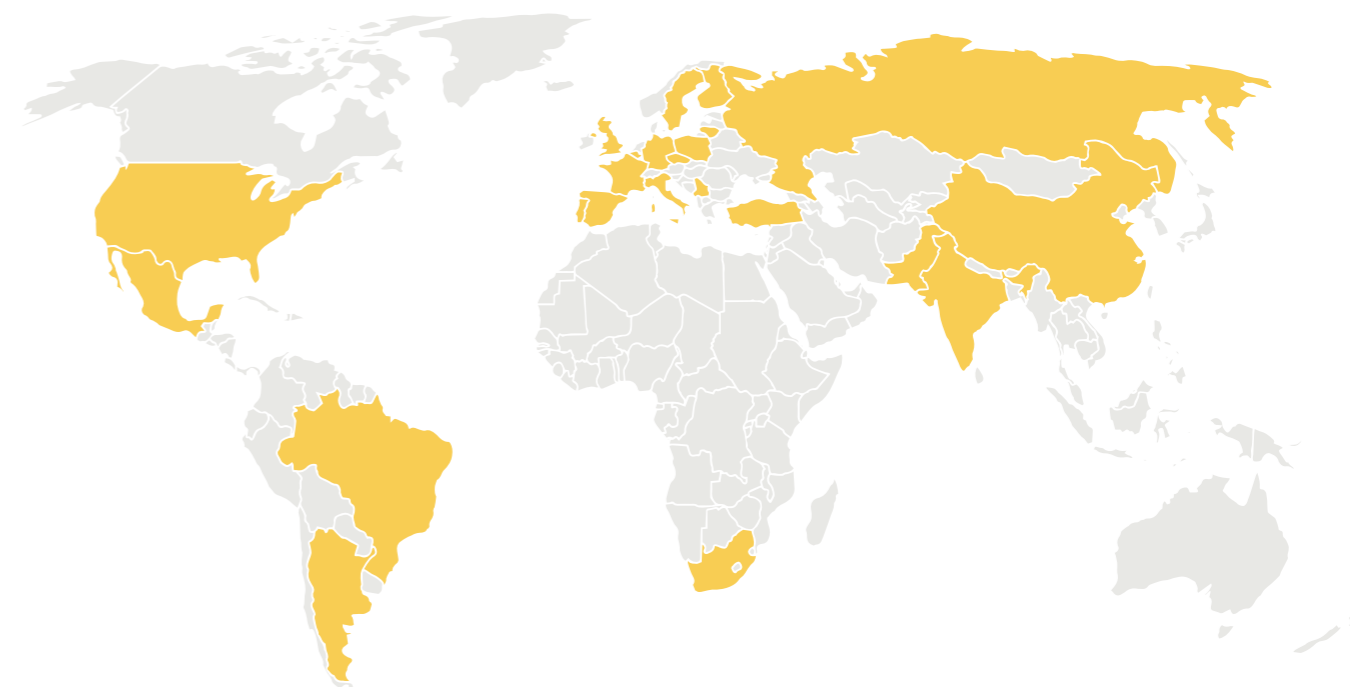

OUR QUALITY

SINTERLEGHE has developed business and organisational strategies targeted at improving the **quality, competitiveness** and **productivity of the company** by leveraging processes and the relentless growth of key skills.

SINTERLEGHE operates in view of product and process improvement according to the standard ISO EN 9001-2008. In 1998 the company introduced a quality management system for its internal processes in compliance with the certified and internationally recognised model.

Quality and development goals are pursued not only through the steady review of products and production processes, but also through the professional development of company resources. In 2016 SINTERLEGHE started a training programme with FESTO Consulting, a major international consultancy firm,

for the development of individual skills prescribed at different organisational levels.

The application of working methods and standards targeted at Total Quality Management, together with the adoption of a new management model based on processes, are targeted at obtaining better performance in terms of productivity, flexibility, responsiveness and reliability.

The higher empowerment and the active involvement of staff in company decisions through targeted actions and plans are a strategic element to accomplish growth and development targets.

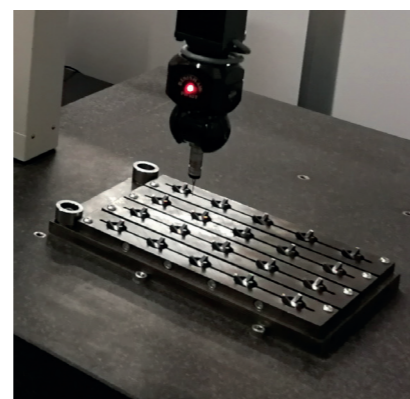
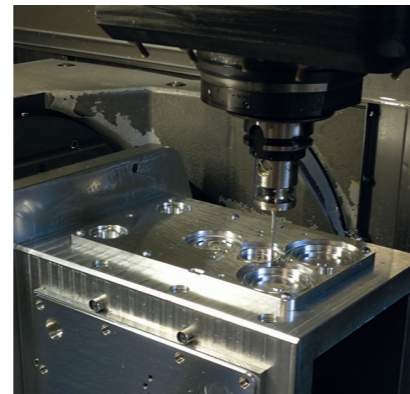

WHY SINTERLEGHE

SINTERLEGHE puts its **expertise, ability** and **professionalism** at the service of its clients. The goal is meeting the most advanced needs in the tip dressing and electrode tip exchange segments by developing a **business process of re-engineering** and **redesign** going through **technology innovation** and steady product and process development.



Technology innovation

SINTERLEGHE's design ideas have turned into patents, as an important guarantee for consumers, certifying the **originality** and **quality** of Ravitex® know-how.



Expertise and know-how

The collaboration with major automotive players worldwide allowed SINTERLEGHE to develop a strong **know-how** and an **in-depth knowledge** of the target market.



Superior quality

Ravitex® products meet the needs of the most advanced production lines, accomplishing ambitious goals in terms of process cost reduction, production capacity increase, quality and environmental friendliness.



Customer care

Ravitex® products result from a careful analysis of clients' needs and requirements. The care for clients prior and after the purchase and their satisfaction are absolute priorities.

RAVITEX® PRODUCTS

The characteristics of Ravitex® products are targeted at the needs of our worldwide clients. Their performance result from intellectual innovation and process quality.



SINTERLEGHE's manufacturing capacity has grown to become more and more flexible over the years thanks to Lean Production and TPS organisational and production methods.

This approach led to optimising internal and outsourcing processes, thereby reducing lead times.

All machining operations are performed in the Anzola d'Ossola (VB) plant with high-output CNC machines. The processes are managed and controlled by a single management software. An air-conditioned metrology room ensures the full dimensional control over the entire manufactured range.

SIGMA POWER SPECIFICATION

The table below shows the details of electrical and pneumatic connections available.

SPECIFICATIONS	EEC SOUTH AMERICA AFRICA - INDIA	CHINA	USA
POWER	0,8 kW	0,8 kW	0,8 kW
FREQUENCY	50/60	50	50/60
SUPPLY	Y 380- 420 V 50 Hz 2A	400 VAC 50 Hz 2A	Y 380- 420 V 60 Hz 2A
SUPPLY	Y 380- 480 V 60 Hz 2A		Y 380- 480 V 60 Hz 2A
SUPPLY OPTIONAL			Δ 230-300 V 60 Hz 3.46A
SUPPLY OPTIONAL			Δ 220-255 V 50 Hz 3.46A
DUTY TYPE	S3-7%	S1	S3-7%
CERTIFICATION	CE	CCC	AM-UL
INTAKE SUCTION DEVICE	450 l/min @ 6 bar	450 l/min @ 6 bar	450 l/min @ 6 bar
INTERNAL Ø AIR SUPPLY PNEUMATIC PIPE	Ø 6,00 mm	Ø 6,00 mm	Ø 6,00 mm
COMPRESSED AIR SUPPLY	5÷8 bar - ISO 8573 Class 3.4.3	5÷8 bar - ISO 8573 Class 3.4.3	5÷8 bar - ISO 8573 Class 3.4.3
DEGREE OF PROTECTION IP	54	54	54
TUBES AND FITTINGS	ISO	ISO	ISO
SOLENOID VALVES	ISO	ISO	ISO

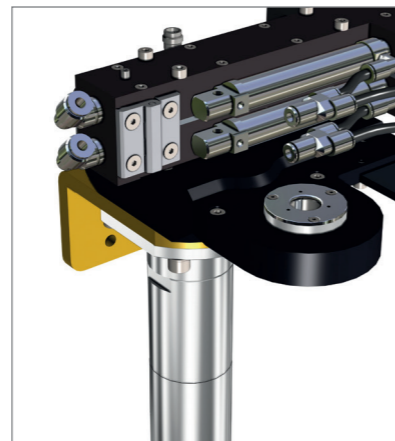
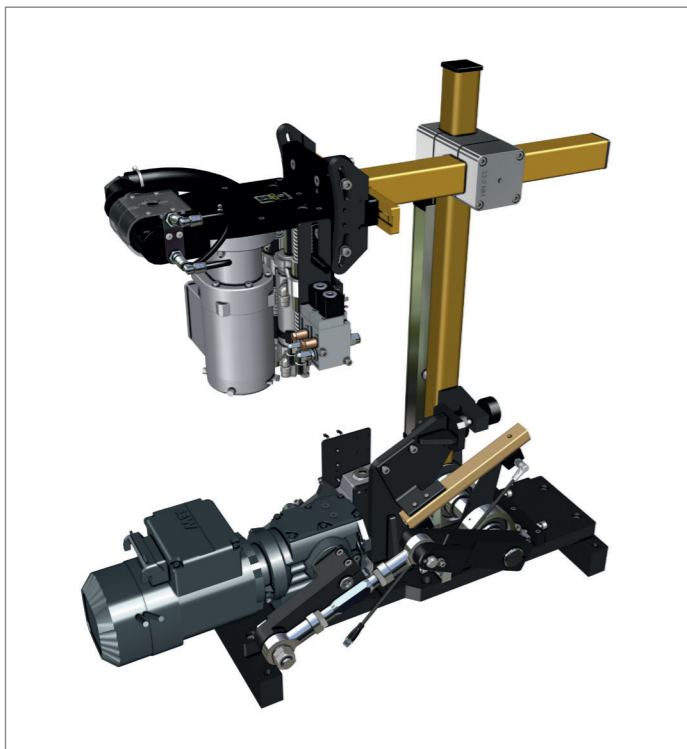
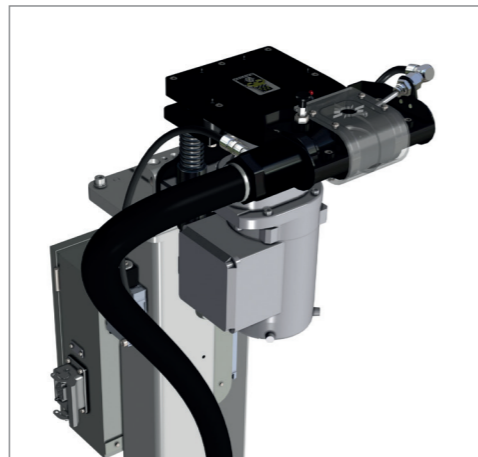
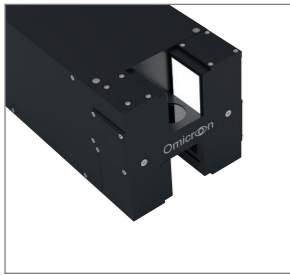

INDEX OF MACHINES & ACCESSORIES

Dresser SIGMA Electric for Robot Welding Guns	10 - 11
SIGMA Changer & Dresser Patent <i>EP 3227046</i>	12 - 13
SIGMA Swivelling Unit	14 - 16
SIGMA Pneumatic Changer Patent <i>EP 3227046</i>	17
SIGMA Manual Dresser	18
OMICRON Optical Sensor Patent <i>EP2938454</i>	19
Accessories	20 - 21

Dresser SIGMA Electric for Robot Welding Guns

Description

- 01 Machines
- 01 Tip dresser
- 01 SIGMA series electric motor
- XXXXX Sequential edited by the SINTERLEGHE Technical office for client's technical specifications

MECHANICAL INTERFACE

- Base Plate
 - (LxW) 300 x 300 mm
 - (Ground fixing holes) 4 x Ø 26 mm holes
 - (Distance between holes) 230 x 230 mm
- Tip dresser's head
 - 2 x M10 screws distance between holes 60 mm
- Head orientation
 - Dressing head adjustable in 2 positions

TIP DRESSER'S FEATURES

Distance cutter center - carter edge	39 mm
Tip-dresser's head height	20 mm
Cutter rotation speed loadless	265 rpm with 1:1
Cutter rotating direction	Clockwise
Tip-dresser's head equalization height	+/- 30 mm

Electric and pneumatic connection: check availability on pag. 7



Better performance with a powerful pneumatic suction device.

Carter is fixed only on upside to allow the fast disassembly for easy maintenance.

Most reliability due to new gears design and to new hardness and surfaces treatments to avoid corrosion.

High cutting torque: power motor up to 0,8kW.

Equalization system:
 - Up to ± 30mm range.
 - Very smooth movements.

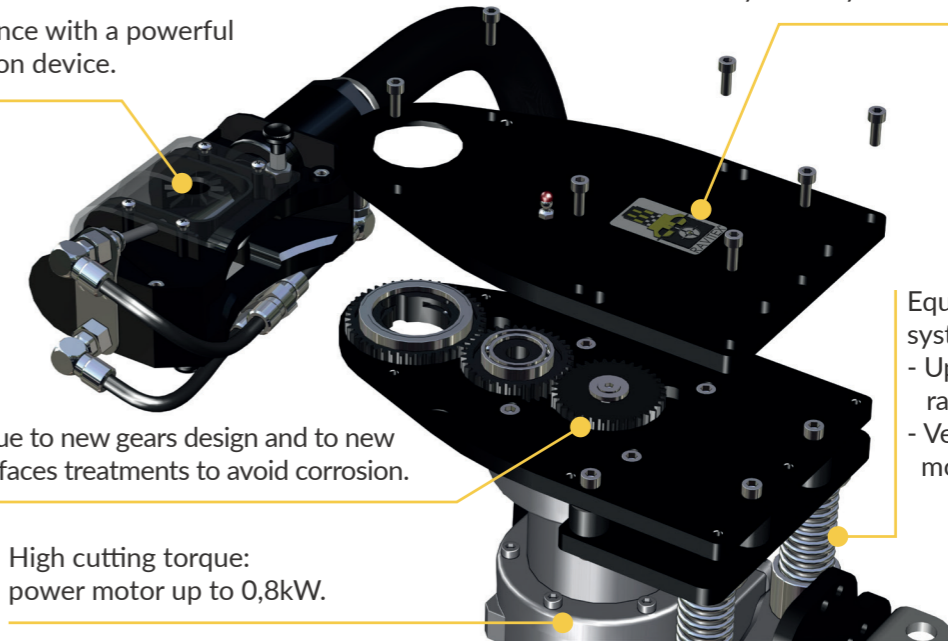

TIP DRESSER VERSION H

TIP DRESSER VERSION V1

TIP DRESSER VERSION V2

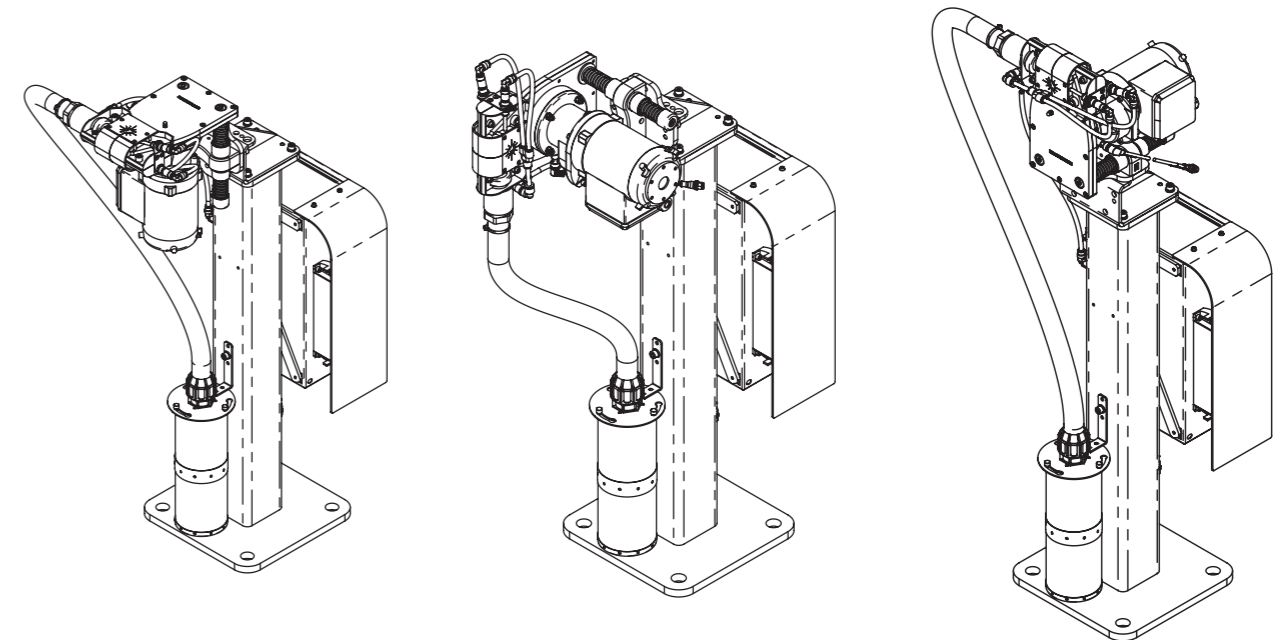

It's possible to configure SIGMA electric dresser in H - V1 - V2 position without any additional options.

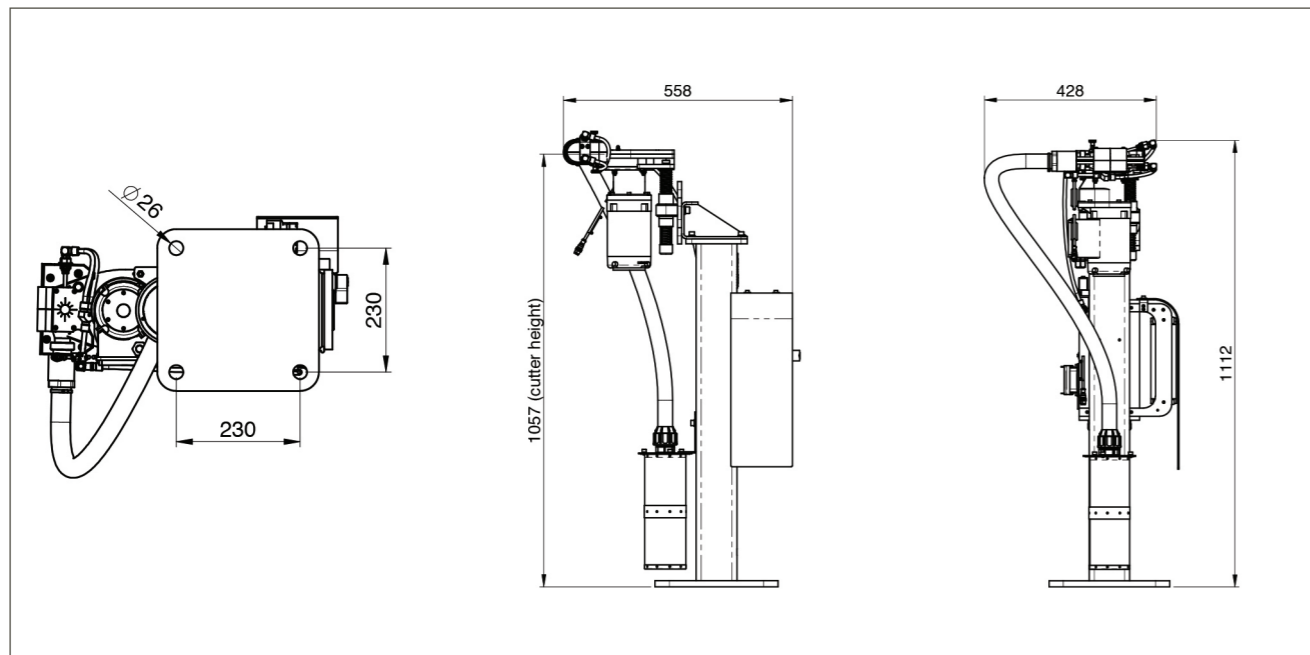

SIGMA Changer & Dresser
Patent **EP 3227046**

Description

01 Machines

06 Tip dresser + electrode changer

01 SIGMA series electric motor

XXXXX Sequential edited by the SINTERLEGHE Technical office for client's technical specifications

MECHANICAL INTERFACE

- (LxW) 300 x 300 mm
- Base Plate
 - (Ground fixing holes) 4 x Ø 26 mm holes
 - (Distance between holes) 230 x 230 mm
- Tip dresser's head
 - 2 x M10 screws distance between holes 60 mm
- Head orientation
 - Dressing head adjustable in 2 positions

TIP DRESSER'S FEATURES

Distance cutter center - carter edge	39 mm
Tip-dresser's head height	20 mm
Cutter rotation speed loadless	265 rpm with 1:1
Cutter rotating direction	Clockwise
Tip-dresser's head equalization height	+/- 30 mm
Bidirectional releasing system Patent 1427232	

Electric and pneumatic connection: check availability on pag. 7

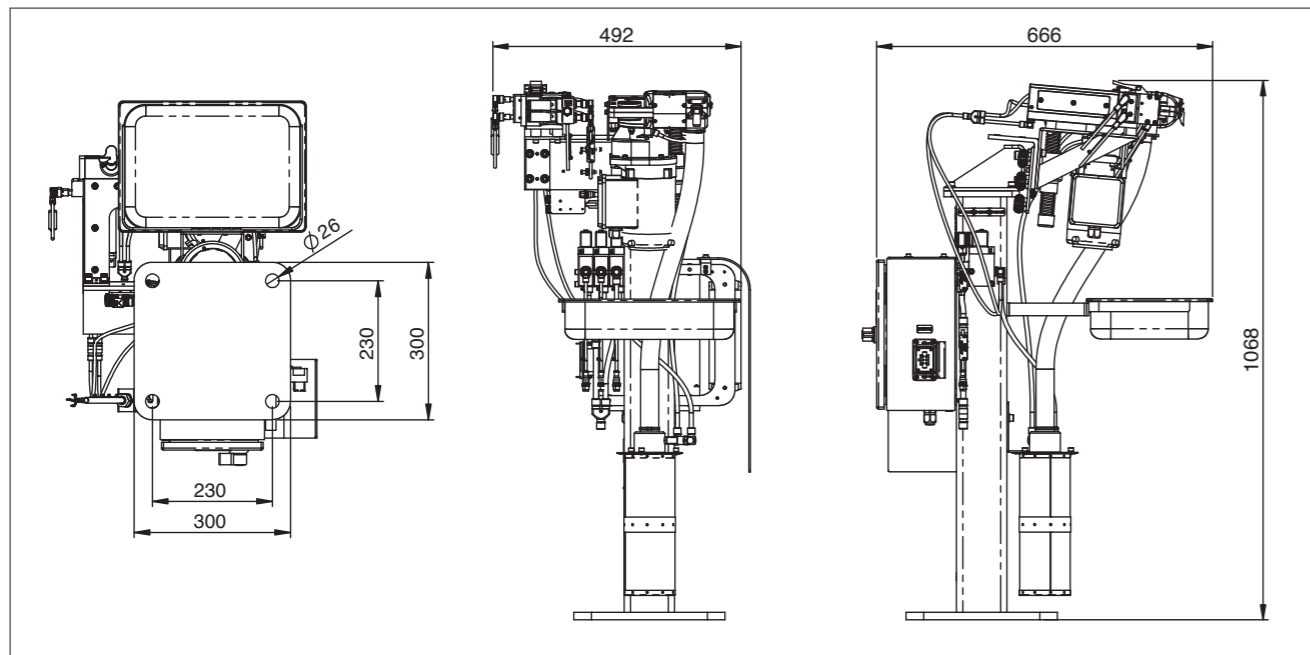
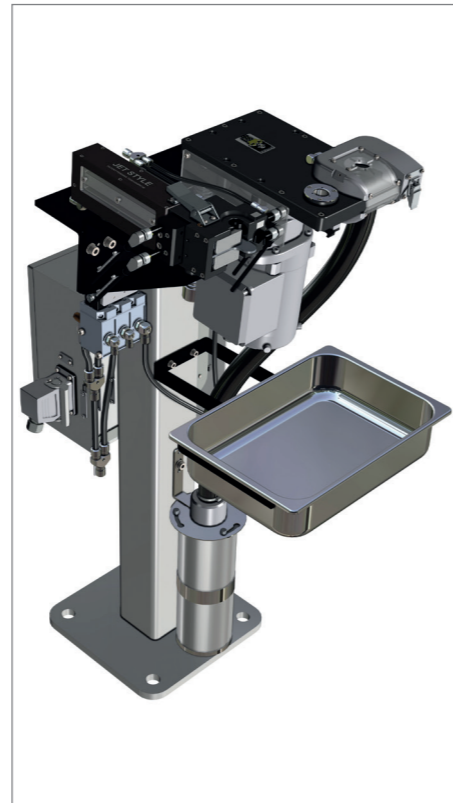

Electrodes Magazine
Patent **EP 3043949**

Total pneumatic movements controlled by robot. Self cleaning feature for each loading by air jet.

Up to 14+14 electrodes Ø16 or 10+10 electrodes Ø20 stored and protected until the loading.

2 sensors to alert the reloading of the magazine.

Possible to load different types of electrodes upside and lowerside.

Integrated fixing plate (optional).

SIGMA CHANGER & DRESSER POSITION H

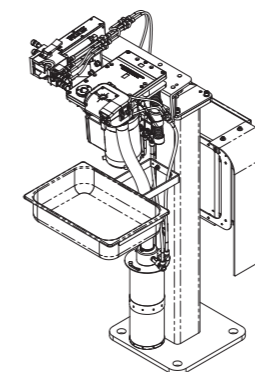

Bidirectionale Releasing System Patent EP 3227046

- Possibility to release electrode from Ø 13 to Ø 20 mm also fixed on screwed holder.
- It's possible to release different type of electrode upper /down side if with the same diameter.
- The release of the electrode is made of 380 millisecond.
- The release upper and down electrode in the same position.
- The force required to release the electrode is auto adaptive from 30 daN at 180 daN at every cycle.
- To each release operation it takes account of the diameter and the oxidation of electrode.

2 sensors to detect the effective presence of the electrodes in the loading bay before and after the loading on the welding gun.

1 sensor to detect the presence of electrodes on the welding gun before and after the loading of the new electrode.

SIGMA CHANGER & DRESSER POSITION V3

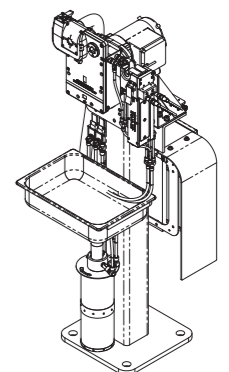

It's possible to configure SIGMA Changer & Dresser in H -V3 position without any additional optionals.

Sigma Swivelling Unit

Description

01 Machines

03 Swivelling Unit

05 Electric Motor without dressing head

01 SIGMA Series electric motor

XXXXX Sequential edited by the SINTERLEGHE Technical office for client's technical specifications

Options

MECHANICAL INTERFACE

Base Plate	<ul style="list-style-type: none"> (LxW) 730 X 180 mm (Ground fixing holes) 6 x Ø 20 mm holes
Tip dresser's head	<ul style="list-style-type: none"> 2 x M10 screws distance between holes 60 mm

TIP DRESSER'S FEATURES

Distance cutter center - carter edge	39 mm
Tip-dresser's head height	20 mm
Cutter rotation speed loadless	265 rpm with 1:1
Cutter rotating direction	Clockwise
Tip-dresser's head equalization height	+/- 30 mm

Electric and pneumatic connection: check availability on pag. 7

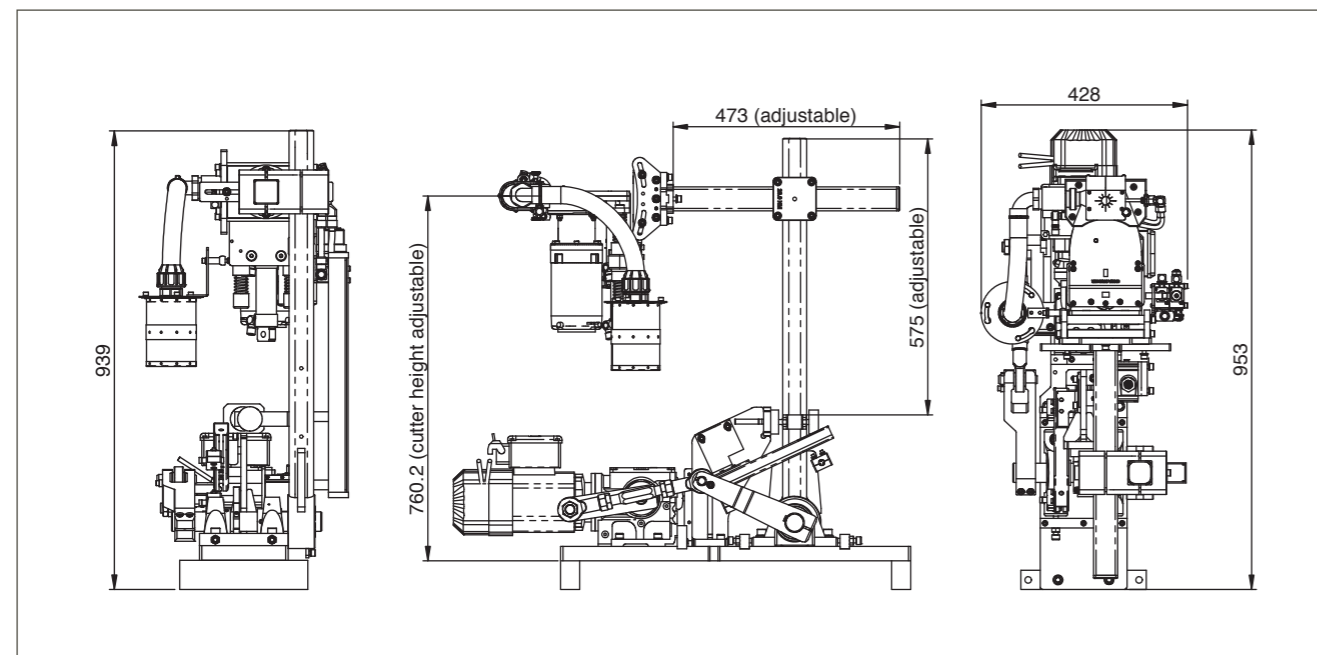
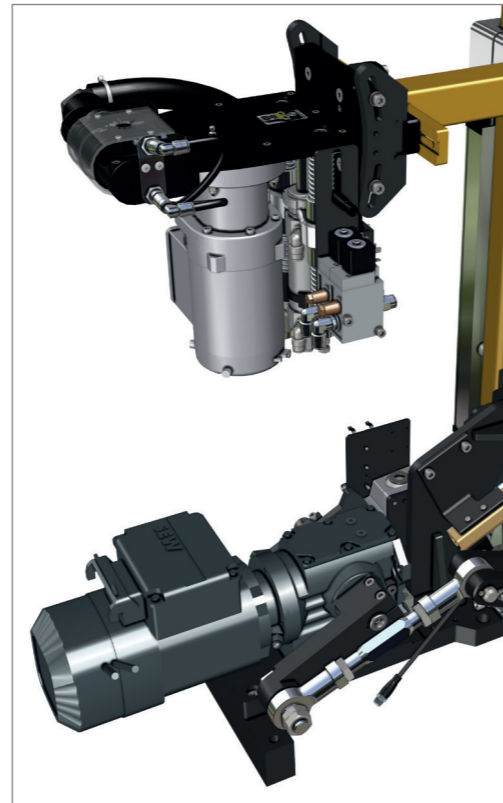

Suction device totally integrated on head.



Head position settings
5 axes fixed 1 axis pneumatic.

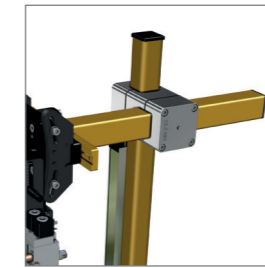

Solenoid valves on head.

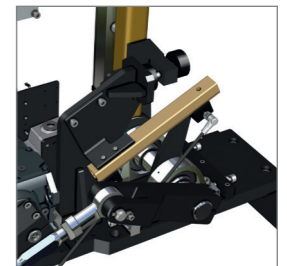
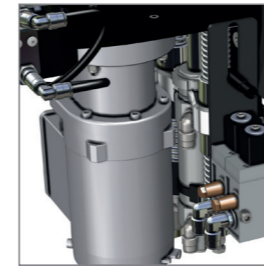

Mechanical stop on dressing position.

Fixed connection plate.

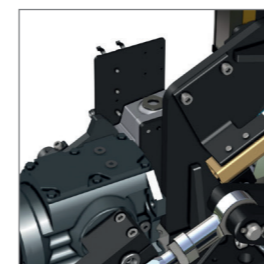

Transmission redesigned.

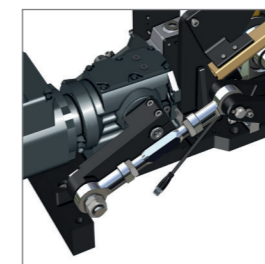

- Collision with the welding gripper impossible thanks to pneumatic head control
- Manual adjustment of the dressing head on 3 axes
- Adjustment of the dressing head positioning arm on 6 axes

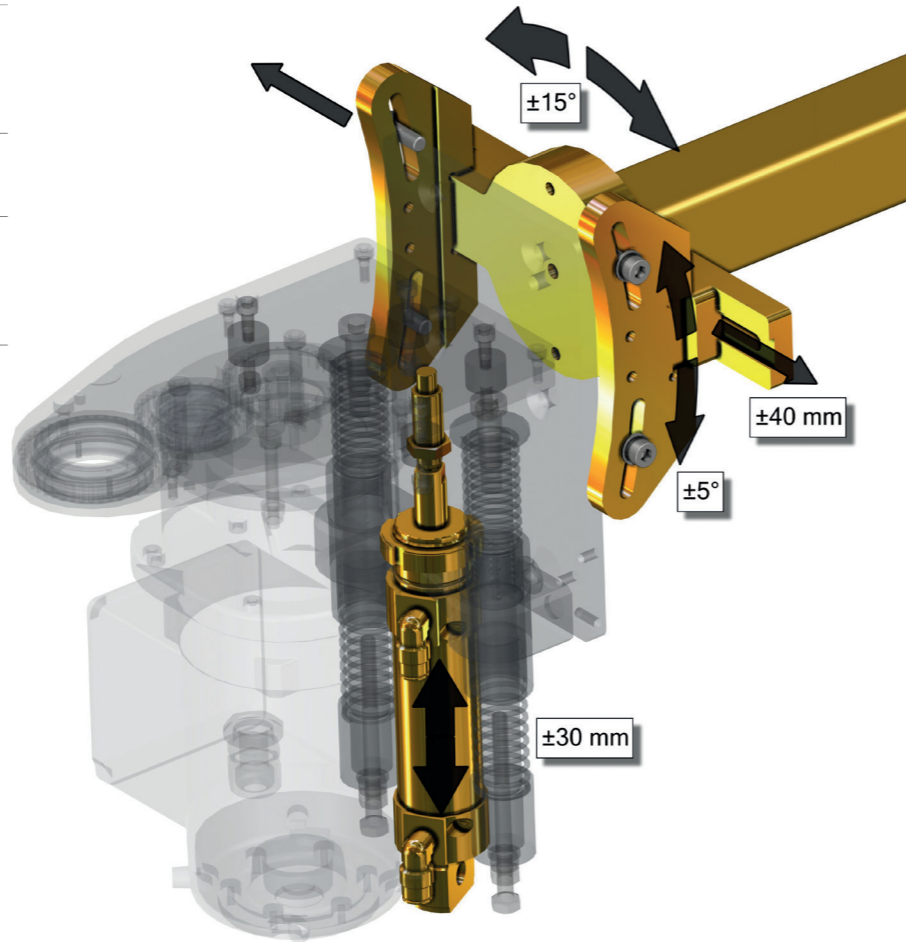

SIGMA SWIVELLING UNIT VERSION 1



SIGMA SWIVELLING UNIT VERSION 3 INCLUDING ADDITIONAL ARM

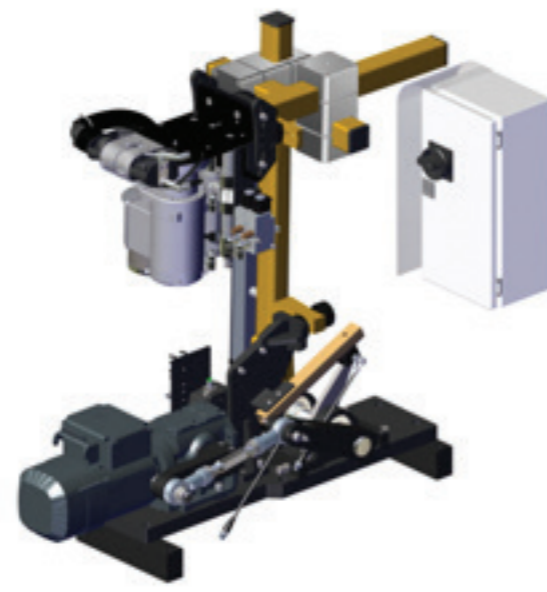

12 different assembly possibility setting head tip dresser: 5 manuals, 1 pneumatic.

SIGMA Pneumatic Changer Patent EP 3227046 for Fixed Welding Guns

Description

- 01 Machines
- 02 Pneumatic electrode changer for fixed welding guns
- 02 SIGMA Pneumatic motor
- XXXXX Sequential edited by the SINTERLEGHE Technical office for client's technical specifications

MECHANICAL INTERFACE

- (LxW) 102 x 75 mm
 - (fixing holes) 4 x Ø 9 mm holes
 - (Distance between holes) 40 x 40 mm
- Head orientation Head adjustable. The height, horizontal angle of the head can be set according to customer's need.

SIGMA PNEUMATIC CHANGER' FEATURES

- Tip-dresser's head height 20 mm
- Cutter rotation speed loadless 90 rpm

+ PLUS

- Bidirectional releasing system patent EP 3227046
- Electrodes magazine patent 1420033 containing up to 28 Ø 16mm electrodes or up to 20 Ø 20 mm electrodes
- Compact overall dimensions

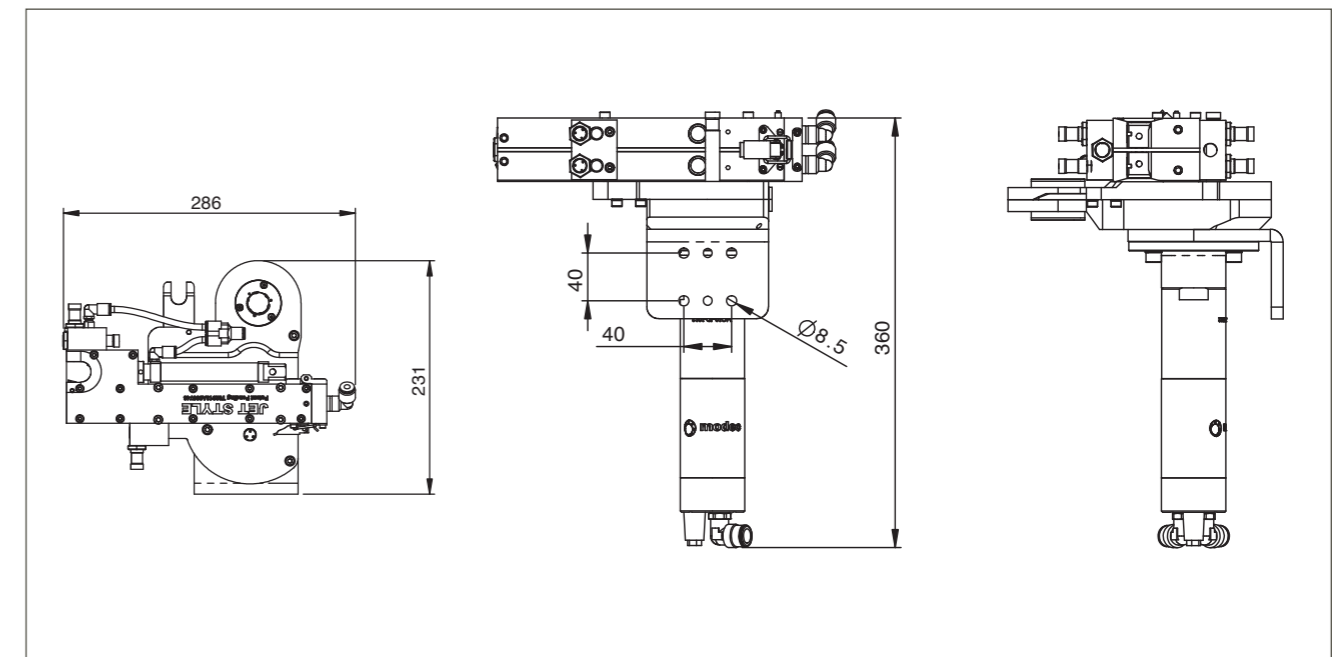

SIGMA Manual Dresser

Description

- 01 Machines
- 05 Manual tip dresser
- 01 Pneumatic operation

XXXXX Sequential edited by the SINTERLEGHE Technical office for client's technical specifications

TIP DRESSER'S FEATURES

Distance cutter center - carter edge	39 mm
Tip-dresser's head height	20 mm
Cutter rotating direction	Clockwise

+ PLUS

- Possibility to mount three blades or single blade cutter
- AIR SUPPLY: 6 BAR ISO 8573 Class 3.4.3
- AIR PIPE SUPPLY:
 - Ø 10 external
 - Ø 8 internal minimum

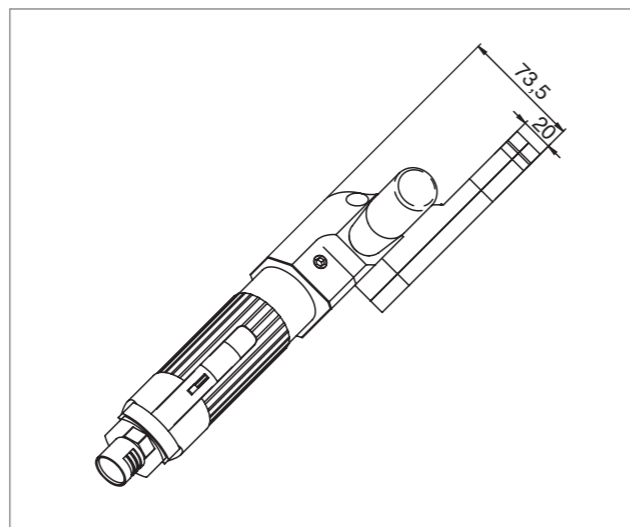
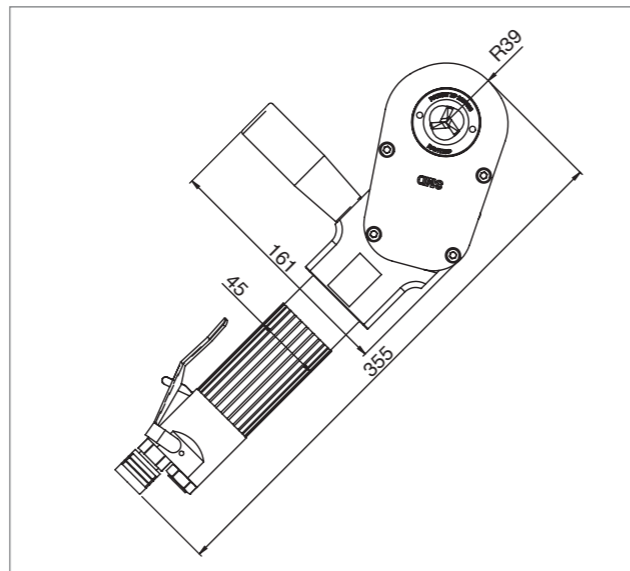
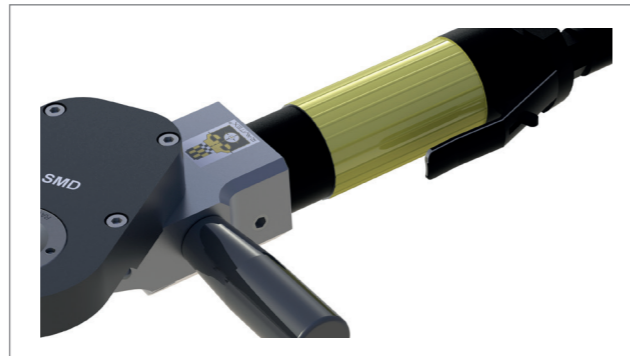

OMICRON Optical Sensor Patent EP2938454

Intelligent sensor for detecting the geometry of the electrode and brightness of the welding lens.



FUNCTIONS

Optical detection and analysis of the level of contamination of the welding lens	Accuracy of 5% in measurement of the contaminated area
Optical detection and analysis of the electrode geometry in order to measure height and estimated deformation of the welding lens	Accuracy of 0.1 mm on dimensional measurements
Integrated logic to establish level of polishing and dressing required to restore maximum welding efficiency	Cost reduction on electrode replacements
Integrated adaptive logic to optimise the maximum number of welding spots performable before further monitoring operation	Optimal trade-off between efficiency of use of the robot, energy consumption and welding quality
Integration of HW/SW with welding cell in accordance with the paradigms of 4.0 industry	
Logging data with functions of simplified extraction of files for offline analysis	
Configuration software based on web technology	

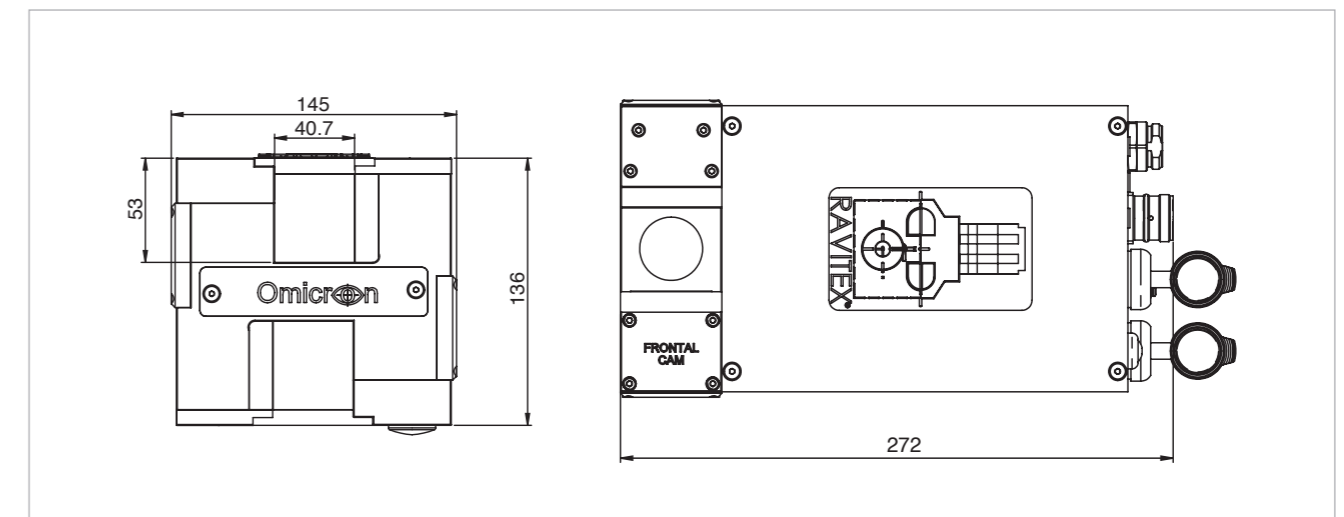

The OMICRON Optical Sensor Patent EP2938454 will be available from February 2018.

RAVITEX® ACCESSORIES

Electrode Extractor Wrench in Steel

Order number
19PA-04380



Electrode Extractor Wrench in Chromed Steel with Hammer

Order number
19PA-01372



Calibration Tool for Welding gun/Cutter

Order number
070101000040
for upper electrode diam 16,00 mm

070101000041
for lower electrode diam 16,00 mm

070101000154
for upper electrode diam 20,00 mm

070101000155
for lower electrode diam 20,00 mm



RRM Manual Tip Dresser

Order number
163R-03633



Partner
MEXICO
AUTOMATICS S.A. DE C.V.
 Hidalgo #33 Col. El Colorado
 El Marques 76246 Querétaro
 City - Estate of Querétaro

 Ing. Víctor Morales Rebollo
 Tel +5221 442 141414
 victor.morales@automatics.com.mx

Branch
BRAZIL
SINTERLEGHE DO BRASIL S/A

 Rua Fábio de Almeida Magalhães,
 nº 207 Sala. 03 - Jardim Stº Elias
 São Paulo SP - CEP 05135-370

 Mr. Pindaro R. Cacheiro
 Tel + 55 11 39030969
 Mob + 55 11 998684294
 pindaro.cacheiro@sinterleghe.it
 massimo.fornasari@sinterleghe.it

Branch
GERMANY
SINTERLEGHE GmbH
 Wieselacker 7A D-35041
 Marburg a.d. Lahn

 Mr. Umberto Adami
 Tel +49 178 5670938
 Fax +49 6421 360453
 umberto.adami@sinterleghe.com

Partner
SPAIN
BAMBU TECHNOLOGY SRL
 Avda. Mare de Deu de Montserrat, 21
 08970 Sant Joan Despi - Barcelona

 Mr. Humberto Ferrer
 Tel +34 932 035 540
 hf@bambutech.com

Head Office
ITALY
Registered office
 Corso Luigi Einaudi, 18
 10129 Torino
 accounting@sinterleghe.it

Manufacturing plant
 Via alla Sega, 10
 28877 Anzola d'Ossola (VB)
 Tel +39 0323 83 78 62
 ravitex.sales@sinterleghe.it

Partner
SWEDEN
SVETSRADET AB
 Soldatgatan 14
 18534 Vaxholm Svezia

 Mr. Stefan Borg
 Tel +46 (0)8-6732330
 Fax +46 (0)8-6732335
 stefan.borg@svetsradet.se

Subsidiary
TURKEY
Ravitex Bileme
 Ekipmanları Alaaddinbey
 Mah. 616. Sk. Zer5 Plaza
 No: 6 B11 Nilufer / BURSA
 TURKEY

 Ms. Menekşe Kardeş
 Tel +90 536 714 96 56
 menekse.kardes@ravitex.com.tr

Partner
INDIA
NATASHA ENTERPRISES
 211, DLF Towers, 15, Shivaji
 Marg, Delhi-110015 / INDIA

 Tel +91 11 42263403
 Mob +91 11 42283196
 Mr. Roshan Taunk
 rt@natashaenterprises.co.in
 www.natashaenterprises.co.in

Partner
CHINA
SHANGHAI FAITH CO., LTD.
 No. 258 Xinzhuan Road,
 Songjiang Discript,
 201612 Shanghai

 Mr. Lin Xia
 Tel +86 5852 7451
 Fax +96 5852 7461
 xl@faithmfg.com.cn

To look for our partner in your Country, visit www.sinterleghe.it
 If you want to become part of our sales network, send an e-mail to: ravitex.sales@sinterleghe.it

REVISION No.	DATE	TYPE OF REVISION
v. 02	06/2019	Reprinting and partners update
v. 01	09/2017	New catalogue



Since 1992 **SINTERLEGHE** has used the RaviteX[®] brand to promote its philosophy and identify its products, by certifying the brand originality and quality. The **RaviteX[®]** logo and trademark are registered and deposited and they can be exclusively used by **SINTERLEGHE S.R.L.**

ALL PRODUCTS ARE TRADEMARKED 

www.sinterleghe.it

SINTERLEGHE S.r.l.

Registered office

Corso Luigi Einaudi, 18 - 10129 Torino (Italy)
accounting@sinterleghe.it

Headquarters & Manufacturing Plant

Via alla Sega, 10
28877 Anzola d'Ossola (VB)

Tel +39 0323 83 78 62

raviteX.engineering@sinterleghe.it